

ED 025 233

JC 680 463

West Valley College Vocational and Technical Advisory Committees.

West Valley Junior Coll., Campbell, Calif.

Pub Date [68]

Note- 40p.

EDRS Price MF-\$0.25 HC-\$2.10

Descriptors- *Advisory Committees, *Community Involvement, *Junior Colleges, *Technical Education,
*Vocational Education

Identifiers- *California

This brochure describes junior college advisory committees as groups of persons who represent industry and assist in organizing curriculum, advise on material procurement, keep the college current on industry practices, coordinate programs with the community, assist in student selection, guide instructors, provide moral support and public relations, and procure instructors. Organization is described in terms of members' personal qualifications, selection and duties of chairmen, duties of college representatives, lines of communication, number and terms of members, and number of meetings. Functions and names of the incumbent members are listed for committees on (1) Civil Engineering Technology, 11 members, (2) Data Processing, 11 members, (3) Electronics, 13 members, (4) Food Services and Restaurant Management, 17 members, (5) Institutional Foods, 15 members, (6) Law Enforcement, 8 members, (7) Licensed Vocational Nursing, 20 members, (8) Medical Assisting, 12 members, (9) Real Estate, 17 members, (10) Technical Drafting, 13 members, (11) Technical Illustrating, 15 members, (12) Textile and Clothing, 8 members, (13) All College Advisory Committee, 39 members. (RM)

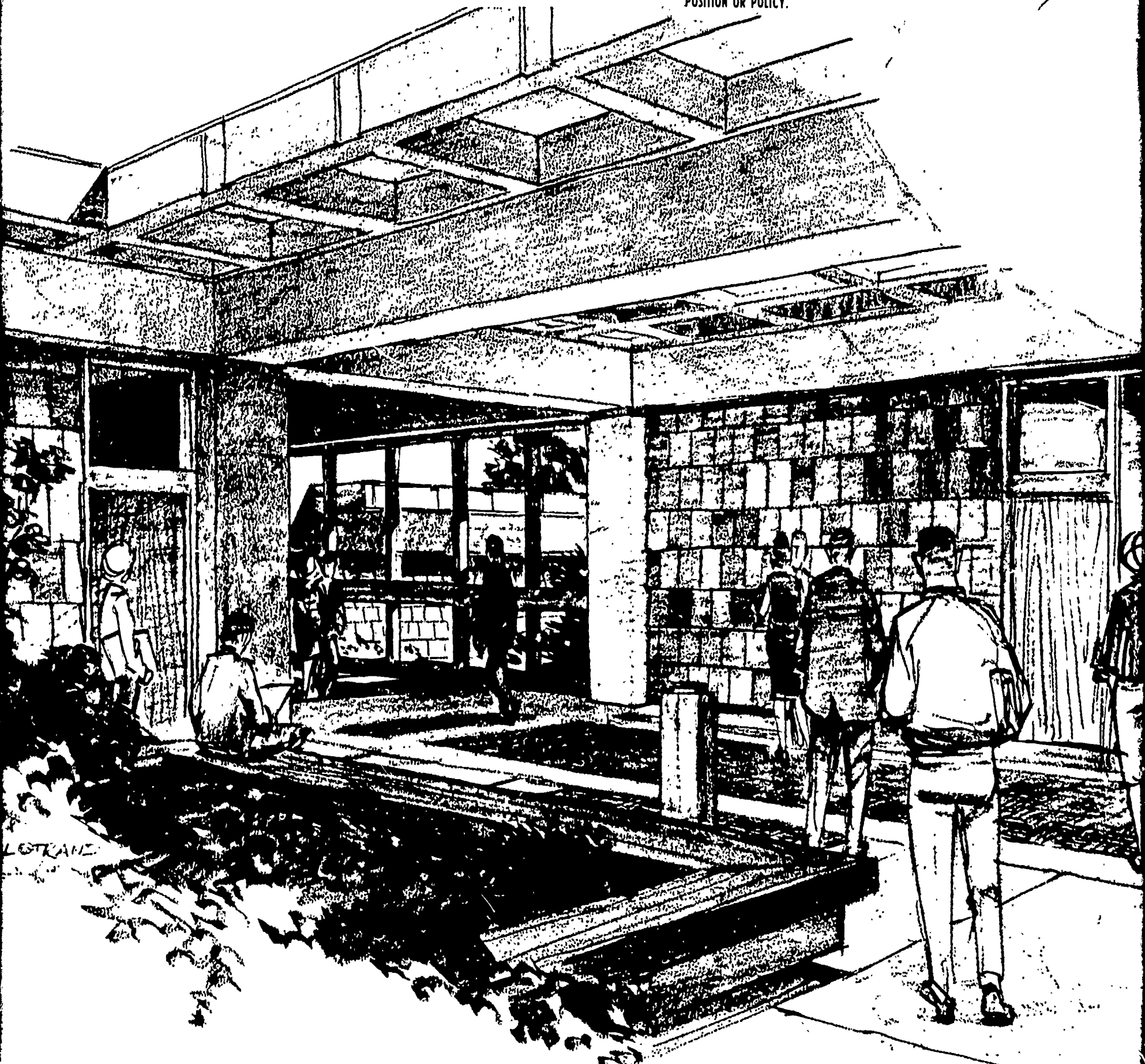

Vocational and Technical Advisory Committees

JC 680 463
ED 025 233

68-69

SARATOGA CAMPUS
14000 FRUITVALE AVENUE
SARATOGA, CALIFORNIA 95050

LOS ANGELES
NOV 4 1968
CLEARINGHOUSE FOR JUNIOR COLLEGE

Engineering Technology Division
West Valley Joint Junior College District

THE WEST VALLEY COLLEGE	4
WHY ADVISORY COMMITTEES?	6
ADVISORY COMMITTEE FUNCTIONS	7
ADVISORY COMMITTEE ORGANIZATION	8
ADVISORY COMMITTEES	10 - 37
Civil Engineering	
Data Processing	
Electronics	
Food Services & Restaurant Management	
Institutional Foods	
Law Enforcement	
Licensed Vocational Nursing	
Medical Assisting	
Real Estate	
Secretarial/Clerical	
Technical Drafting	
Technical Illustration	
Textile & Clothing	
STUDENT CREDITS	39



THE GOVERNING BOARD – Left to right, Mildred Wharton; Robert A. Sorensen; Donald E. Lindstrom, Chairman; Robert W. Brydon; Edward A. Panelli, Clerk; Jack Armstrong, Vice-Chairman; William J. Homan.

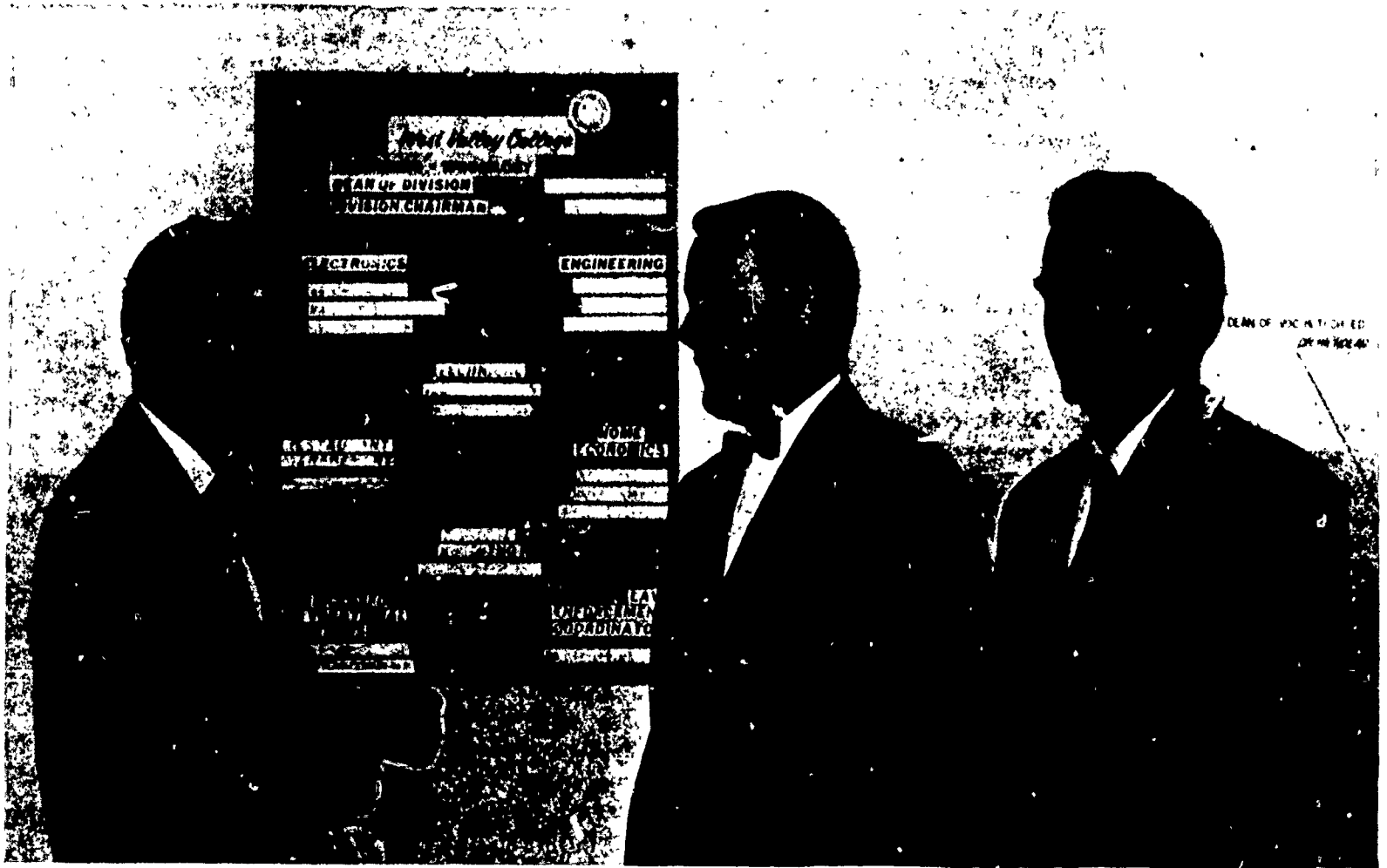

Mr. A. Charles Tyler, Engineering & Technology Counselor
Dr. Albert J. Riendeau, Dean of Vocational-Technical Education
Mr. George Grubb, Engineering & Technology Division Chairman



Cover & Layout by Lawrence Tessier,
Graduating Engineering Technology student.

The West Valley College Philosophy

West Valley College is a community college. It serves the residents of a large district in the Santa Clara Valley which is made up of three high school districts: Santa Clara, Campbell, and Los Gatos High School Districts. The College provides education and services in four main areas:

- 1) Vocational and technical education in the areas of applied arts and sciences, business, engineering technologies, health sciences, and public and social services.
- 2) Two years of university pre-professional education which can be transferred to four-year colleges and universities.
- 3) Opportunity for continuing and broadening educational courses and programs for adults who may wish to expand their educational and cultural experiences.
- 4) Community services in various areas so that those who desire may broaden their cultural and educational background.

The college maintains an open door policy which permits college-age youth and adults who can benefit from higher education to take advantage of the opportunity which has been provided for them.

Primary attention has been given to the development of vocational-technical curriculum to meet existing needs in the greater San Francisco Bay Area. The food services and restaurant management program and the allied health programs, are examples of curricula that are based upon community needs and employment opportunities.

West Valley College uses community facilities wherever possible to supplement campus facilities; classroom activities

with industrial and business experience is thus provided in an occupational setting. The internship programs for students from the medical assisting, secretarial, nursing and other programs of education are intended to provide real life working situations. The transition to the world of work upon graduation thus becomes a pleasant experience as the students are productive employees when they complete the program of study.

The general program of institutional research followed by West Valley College is applied to each occupational education program and its graduates. Some of the specific objectives toward which the efforts of the college are aimed include:

- 1) Reducing the number of students who leave or drop out of College before satisfactory completion of work.
- 2) Assessing the degree to which the curriculum and instruction are adapted to the full range of student community needs.
- 3) Improving the effectiveness of technical and occupational curricula.
- 4) Evaluating the competency of placement services.

A major effort is being made to measure the effectiveness of the vocational and technical courses by follow-up studies of the graduates of these courses. How well was the job of preparing them for industry done by the college? Former students are asked to pause in their work for a moment so that others might profit from their considered opinions. Key college personnel are actively engaged in community projects, others hold membership in civic organizations, while still others have maintained affiliations with industry in the interest of meeting community needs.

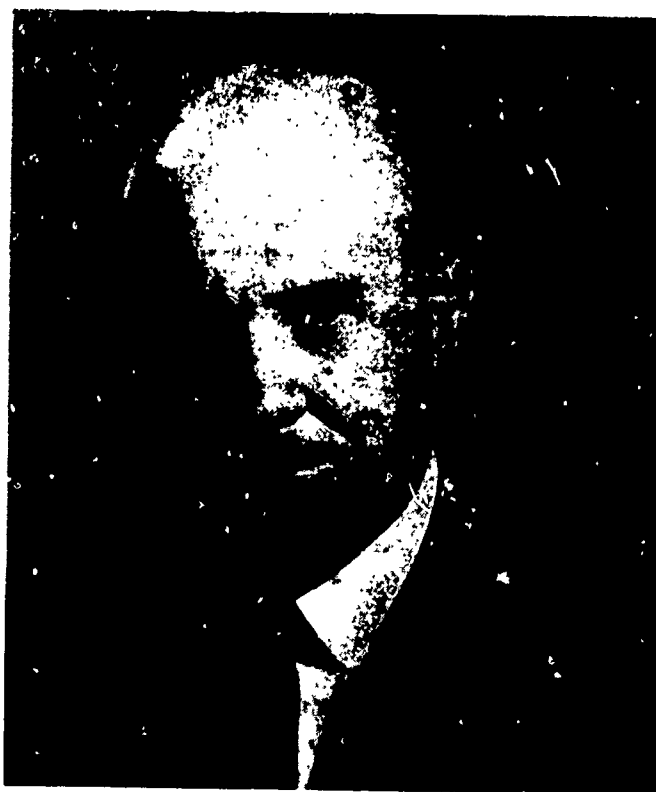

Foreword

Junior colleges place a high value on the services of their advisory committees. They look to them for guidance in the development and continuance of many of their educational programs, particularly those in the technical and vocational areas. This, of course, is especially true in the case of a new and growing college such as West Valley College.

We know that community colleges are closely related to the social forces at work in their immediate locales. Indeed, a community college which is not closely identified with the community which it serves is not fulfilling its high purpose. A society usually sees itself reflected in its schools, and conversely, the schools and colleges are reflected in the society of which they are a part. While neither image may be perfect, nevertheless the consistency of image is there.

The real task of the community college, such as West Valley College, is the development and perpetuation of the necessary skills for maintaining and improving the image of the community. This can best be accomplished with the help of locally oriented Advisory Committees. Schools and colleges throughout our land are looking to these "experts" for assistance in providing training programs that are attuned to the times and designed to serve their respective community's needs.

The Governing Board of the West Valley Joint Junior College District joins me in expressing our heartfelt thanks to the Advisory Committee members listed in this handbook. They are showing us the way that our college can more effectively serve the West Valley Community.

WALLACE W. HALL
Superintendent-President

Why Advisory Committees?

The Engineering Technology Division at West Valley College would be hard pressed to provide adequate training for its students without local cooperation. The active participation of the community's manufacturers, engineers, distributors, entrepreneurs, dealers and service technicians is solicited to work and plan with the college's administrators and instructors.

The broad field of occupational education is constantly expanding its requirements. The need for more knowledge, experience and skill among the electronic technicians, draftsmen, engineering technicians, and in the health and service occupations continues to increase. These technological advances require the joint effort of school and community to remain abreast of changing needs.

One of the early recommendations of the Governing Board in 1963, when it became apparent that West Valley College would almost immediately be offering training for skills which were in short supply, was for the establishment of local advisory groups. These special groups were to be composed of industry representatives who were aware of and interested in the local situation, and who, together with college

administrators and instructors, would bend their efforts toward:

1. Assisting the college in organizing its vocational-technical education curriculum
2. Advising on material procurement
3. Acquainting the college with current practices and developments within the industry
4. Acting as program coordinators to generally guide training so as to best fit the current needs of the greater community's industries.

The controlling purpose of vocational-technical education is to fit its two-year graduates for useful employment or advanced education. This cannot be accomplished without a constant exchange of information to keep the program realistic to fit the changing needs of industry. Only with a properly functioning advisory committee can educational authorities develop vocational and technical education programs based on the real needs of the community. These key people from industry help to acquaint the schools with trends, technical advancements and the varied requirements of industry for specific skills and training.

An Advisory Committee, sensitive to the daily needs of local industry, can provide the effective interchange of information so vital to both school and industry. It provides a link between the school and the community through which occupational activities are coordinated.

Advisory Committee Functions

While occupational needs surveys from time to time focus attention on skill shortages (and surpluses) which are of vital concern to the schools and colleges in a community, the Advisory Committees help to determine and verify the training

needs. Because they are a vital part of the community, they can help the educator in maintaining a level of practical instruction which has real meaning for both youth and adults in terms of conditions in the community.

The Advisory Committee serves to evaluate training programs at the junior college level to ascertain whether or not they provide the kind of training which life situations demand. When course outlines are prepared, representatives of the industry are consulted in order to make sure that the techniques being taught are in keeping with the specific and current requirements of the industry. Instructional materials, equipment, standards for production work, and course outlines are reviewed periodically by the advisory committee in order that they may be kept up-to-date and functional.

Student Selection

Some advisory committees are more effective than others in the selection of students for special programs. The admission recommendation by a committee member for a particular training program carries special weight at West Valley College. Since the Advisory Committees help set up standards for entrance into occupational education programs, the students whom they recommend are usually highly motivated and reflect some of the wise counseling of the Committee member.

Guiding the Instructor

Most instructors find that working with an Advisory Committee is a stimulating experience. He receives encouragement and increases his confidence through this association; the burden of responsibility is lightened as it is shared.

The instructor has learned that the chances for success of a new enterprise are enhanced when appraised by those who are qualified to judge!

Moral Support

Individual Advisory Committee members have appeared at public hearings and spoken before civic gatherings in the interests of improved occupational education. Obviously, only when the citizens know about the achievements and needs of

these occupational programs will they have an intelligent basis on which to consider the financial needs of the College.

It is hoped that as various organizations in the community, such as unions, manufacturers, associations, service clubs, and other civic groups, know the objectives and needs of West Valley College, they will be more likely to support legislation which will strengthen occupational education programs.

Public Relations

West Valley College's wholehearted endorsement of Advisory Committees for its vocational-technical programs is its way of saying: "Ours is an open-door college; our programs are planned for the benefit of the community - we are here to serve the public."

One of the greatest services rendered by Advisory Committees is the interpretation of the college educational program to the people of the community. They bring about an understanding of the purposes and functions of the vocational-technical program and an appreciation of how the school is meeting its responsibilities. The increased community interest in these programs at West Valley College is a direct result of its active Advisory Committees.

Instructor Procurement

Several of the Advisory Committees have already rendered an important service to the college by helping to secure competent instructors. Their recommendations for candidates are actively sought from time to time as needs arise. In addition to encouraging top craftsmen from industry to become teachers on a full or part-time basis, they have served as screening committees to narrow the field of applicants for final selection by the College Governing Board and Administration.

Advisory Committee Organization

Since the college is anxious to work with the people in the community who can contribute most to the success of the occupational education program, appointments to Advisory Committees demand considerable discretion. The success or failure of these committees depends upon the ability and willingness of the members to contribute.

Personal Qualifications

At least three essential criteria are kept in mind when selecting and inviting individuals for membership in one of the West Valley College Occupational Advisory Committees:

1. Experience — Members must have had successful first-hand experience in the special area being served. They are persons who have the respect and confidence of their associates.
2. Adequate time — Since an advisory committee should meet as frequently as necessary, members must maintain close contact with the activities of the school. It will be necessary to devote some time to committee work, some of which will be on the college campus. In this connection, it may be advisable to provide alternates for each member.
3. Character — Most members are invited to serve on the West Valley College Advisory Committees at the recommendation of their colleagues. They are described as exhibiting a strong sense of responsibility and civic-mindedness, and are considered highly cooperative by their immediate supervisors.

The final authority for approval of selected committee members rests with the West Valley College Governing Board. The Advisory Committees listed in this handbook required board action at a regular Board Meeting and their appointment became an official matter of record.

In addition to considering the personal attributes of the individual members, every effort is made to have truly representative committees. These committees, it will be noted, are selected from a cross section of organizations in the community, from several geographical areas in an attempt to achieve balance.

Advisory Committee Operations

West Valley College has its own unique problems to meet; therefore, the Advisory Committees may operate somewhat differently to Advisory Committees at other colleges. The following generalizations are made regarding the College occupational education Advisory Committees and their methods of procedure.

Selection of Chairman

Most of the Advisory Committees were formed by the time classes started in September each year. However, due to the press of forming new programs, a few committees have held their first meetings late in the fall semester, with all Committees having met at least once by the end of the fall semester.

Since the persons who most needed the help were the college representatives, they served as acting chairmen at the early meetings. As time went on and the members became better acquainted, the committees were expected to appoint their own chairmen from among the lay members and representatives of the college.

Duties of the Chairman

The chief duty of the chairman is to preside at all meetings of the committee. He is expected to work closely with the college administration at all times and is consulted when the agenda for the meeting is prepared. It is usually the responsibility of the chairman to appoint sub-committees and to represent the Advisory Committee when appropriate.

Who Represents the College

The most logical individual to assume the task of representing the college at the Advisory Committee meetings is the dean of vocational-technical education. As the college occupational programs expand and meetings increase, it becomes physically impossible for one person to represent the college at all meetings, therefore a representative who is knowledgeable in the special area will be appointed to speak for the college. In addition, the instructors of the particular department under discussion will work with the Committee and assist at the meetings.

Duties of the College Representative

The college representative will serve as chairman, secretary, or general consultant of the Advisory Committee, or a combination of these. It is important to note that in any event, he is considered an ex-officio member of the Committee. He is present to seek advice, not to give it.

Some of his duties will include reading and keeping minutes, notifying members of time and place of meeting, arranging for meeting rooms at the college, providing statistical or descriptive information concerning the college, and preparing reports of progress. The college will assume the tasks of providing all clerical assistance needed in the work of the Committee, including minutes, reports, recommendations, and special notices.

One of the chief duties of the college representative is the preparation of the agenda for each meeting. It is his responsibility to state the problems involved in the occupational education programs and to present them to the Advisory Committee for discussion and recommendations. It is important that members of the committee be consulted in order to discover what the laymen believe to be weaknesses in the program and to get new, original ideas for improvements and additions.

It has been said that achievements of Advisory Committees are in direct relation to demands made on them by schools and colleges. It therefore behooves the

college representative to obtain the maximum benefits from these specialists through active participation at meetings.

Lines of Communication

It has been the practice at West Valley College to send copies of the minutes, including recommendations, to all individuals and agencies involved. This has included administrative officers of the college, the several division chairmen at the college, and the organizations represented by the Committee members. Thus the thinking of the Advisory Committee is made available to all interested persons, and the college authorities may use the suggestions as they choose.

Number of Members

The number of members on an Advisory Committee varies with the nature of the program served. This group should not be so large that it becomes cumbersome to deal with. It should lend itself to informal, constructive discussion.

Term of Membership

Members are appointed to definite terms of office serving from one to three years. Provision is made for staggered replacement so that there will always be old, experienced members serving. When a term has expired, a new committee member will be appointed with the approval of the Governing Board. Members may be reappointed for a new term at the request of the College representative.

Number of Meetings

With an ever expanding campus and programs to match, it has been difficult to standardize the number of meetings that each Advisory Committee should hold during the course of a year. The practice of calling meetings whenever there is important business to be conducted will be continued during 1968-1969. Calling the Committee together for meetings to discuss matters that might have been resolved by mail will be avoided by the College in deference to the already heavy demands of the jobs of most committee members.

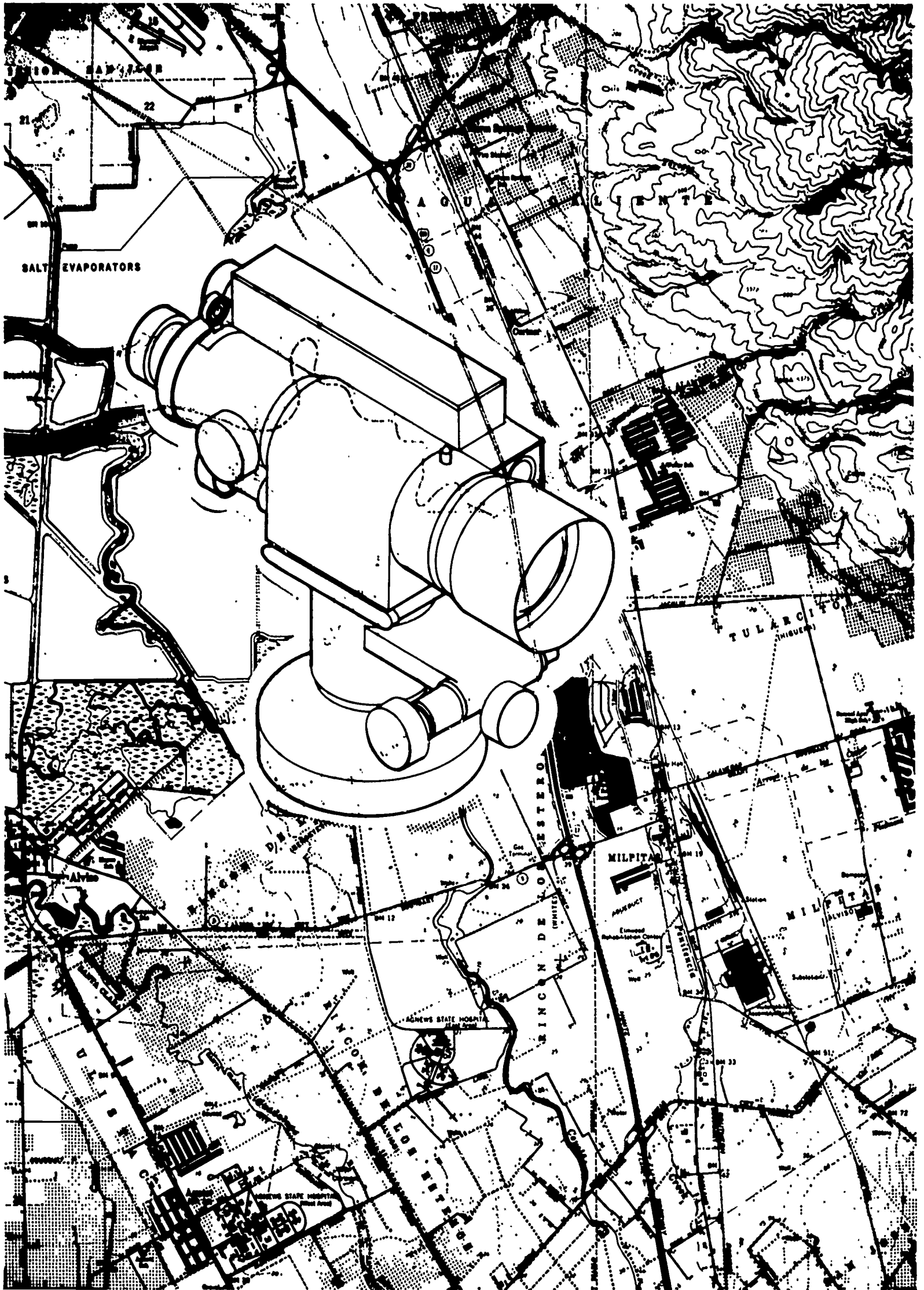

This curriculum provides the basic educational preparation for technological activities in the fields of civil engineering and construction. Particular emphasis is placed upon the fundamental engineering principles required in civil engineering practice. Basic experience in field surveys, drafting, and laboratory testing is also provided.

ADVISORY COMMITTEE

Mr. Tom Fox, Sr. Highway Engineer
California State Division of Highways
150 Oak Street, San Francisco
557-2141

Dr. Henry V. Hahne
Chairman, Dept. of Civil Engineering
University of Santa Clara
820 Alviso, Santa Clara
296-3360

Mr. James R. Huff, City Administrator
City of Saratoga
13777 Fruitvale Avenue, Saratoga
867-3438

Dr. Robert H. Keyser
Associate Prof., Civil Engineering
University of Santa Clara
820 Alviso, Santa Clara
296-3360

Mr. Harry N. Lalor, Associate
Ruth, Going & Beck
Consulting Engineers
919 The Alameda, San Jose
297-8273

Mr. Thomas Morrison
Personnel Assistant
Pacific Gas and Electric Company
86 South 3rd Street, San Jose
298-3333

Mr. Frank Pisano, Consulting Engineer
Frank Pisano & Associates
333 North 26th Street, San Jose
292-9510

Mr. Brainerd Plehn
Consulting Engineer
394 So. San Antonio Road, Los Altos
948-1511

Mr. Edward Steffani
Co. Engineer, Santa Clara County
20 West Hedding Street, San Jose
299-1121

Mr. William Trigerro, City Engineer
City of Santa Clara
1500 Warburton Avenue, Santa Clara
243-7010

Mr. William G. Wren
City Engineer, City of Campbell
75 North Central Avenue, Campbell
378-8141

WEST VALLEY COLLEGE
379-1733

Mr. George C. Grubb, Jr. Instructor
Engineering-Surveying

MEETING SCHEDULE:
Called as Needed.

Data Processing

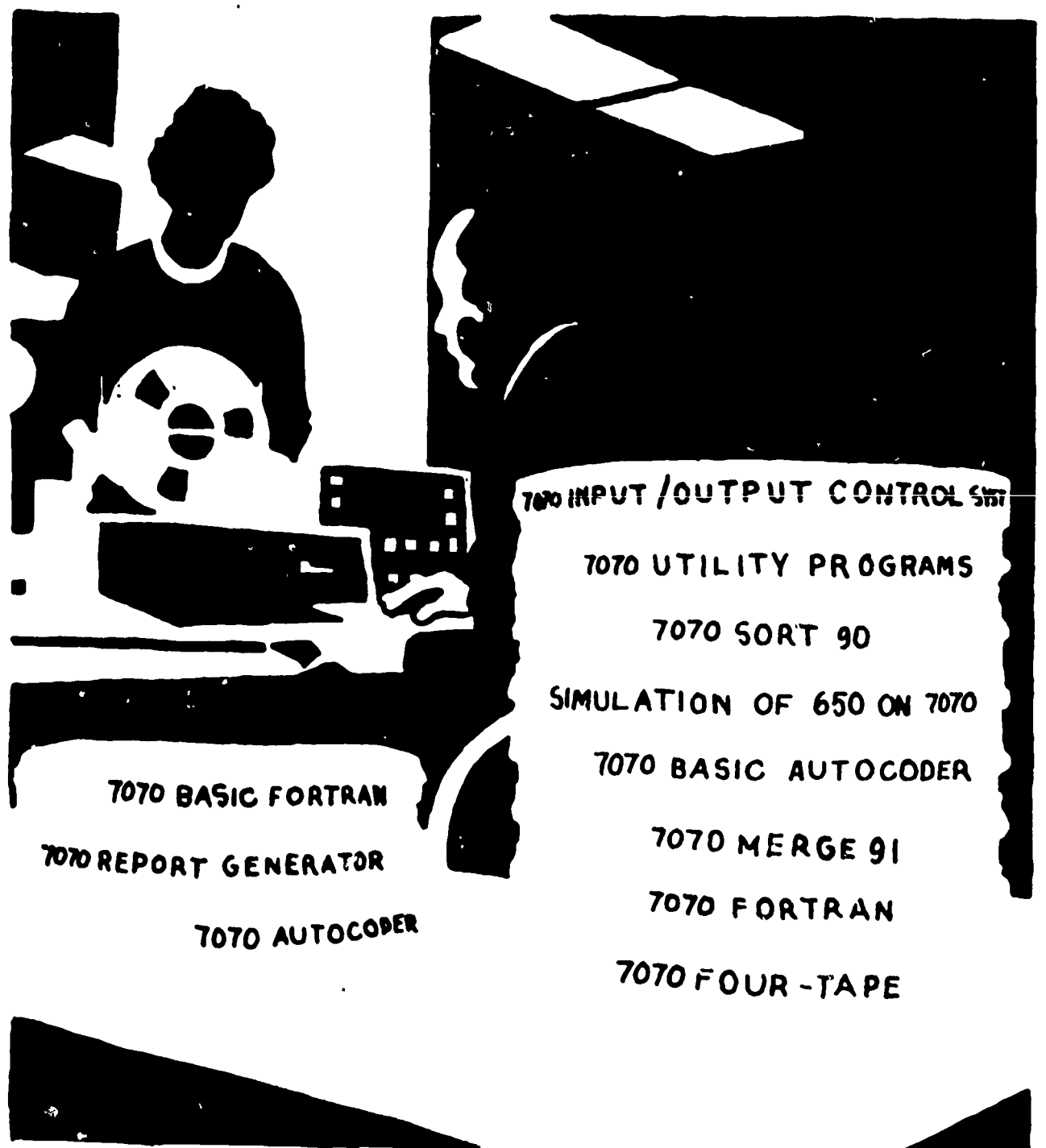

The Electronic Data Processing curriculum is designed to provide services for the total industry and not just segments of it. It is the processing of information which is expressed in alphabetic and numeric form and has application in three broad areas: engineering and scientific research and application, research development in management science, and control of business operations.

ADVISORY COMMITTEE

Mr. L. H. Amaya, Manager
Computer Center
Lockheed Missiles & Space Co.
Sunnyvale
742-4567

Mr. James V. Brown
Data Processing Coordinator
Controllers Department
FMC Corporation
P. O. Box 760, San Jose
289-2671

Mr. B. C. Dove
Director of Marketing
Mellonics Systems Development Div.
1001 West Maude Avenue, Sunnyvale
245-0795

Mr. C. H. Finnie, Jr.
Computer Programming Supervisor
D/59-32
Lockheed Missiles & Space Company
Sunnyvale
742-2401

Mr. Daniel Hochman
President, Dacom, Inc.
3980 Fabian Way, Palo Alto
328-0200

Mr. R. Dean Kunkle
Data Processing Manager
Granger Associates
1601 California Avenue
Palo Alto
321-4175

Mr. O. C. Phipps, Jr.
Computer Group Supervisor
Philco-Ford Corporation
Palo Alto
326-4350

Mr. George Vandermate
Director, D. P. Department
County of Santa Clara
70 West Hedding, San Jose
299-3611

Mr. D. G. Wyman
Systems Programmer, I. B. M.
18691 Casa Blanca, Saratoga
227-7100, Ext. 3324

WEST VALLEY COLLEGE
379-1733

Dr. Albert J. Riendeau, Dean*
Division of Engineering-Technology

Mr. Woodrow H. Wilson, Chairman
Data Processing

MEETING SCHEDULE:
Called as needed.

*As Dean of the Division of Engineering Technology, Albert J. Riendeau is an ex-officio member of each advisory committee within the division.

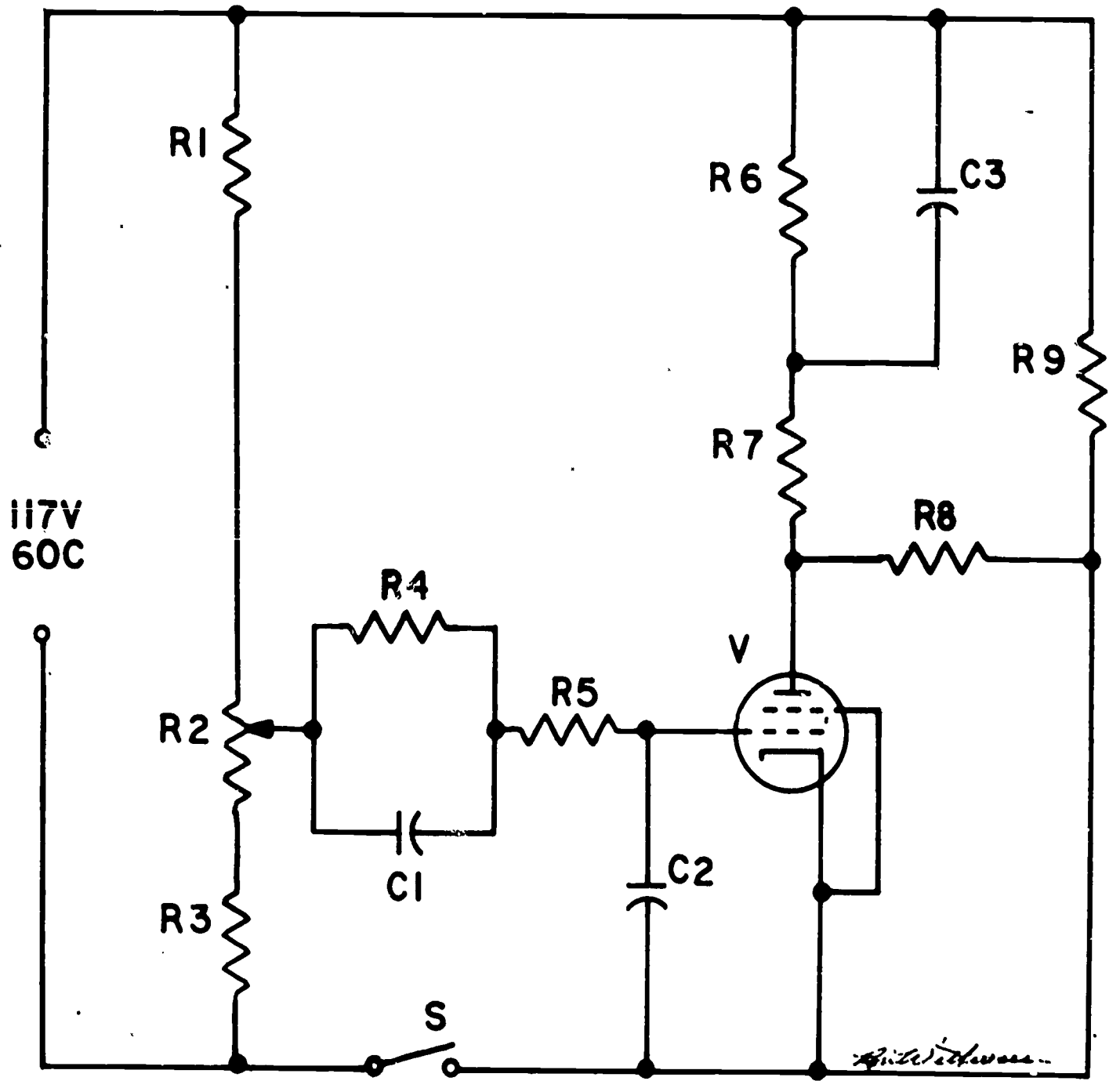

Electronic technicians are in high demand by many industries in the Nation, especially those who are concerned with aerospace, air traffic control, communications and automation. Santa Clara County industry, with its emphasis on missiles and space craft, and on research and development, has been absorbing all graduates of this program. Courses in mathematics, science, mechanisms, television fundamentals, industrial control circuits, and associated subjects make up the electronic technician program.

ADVISORY COMMITTEE

Mr. Robert Bain
Stanford Research Institute
Menlo Park
326-6200, Ext. 3617

Mr. Steve Banks, Field Manager
I. B. M. Corporation
1955 The Alameda, San Jose
248-2620

Mr. John D. Courtney, Manager
Operational Programs Engineering
General Electric Company
355 W. Olive Street, Sunnyvale
245-4900, Ext. 32

Mr. Dave Johnstone
Technical Training Coordinator
Hewlett-Packard Company
1501 Page Mill Road, Palo Alto
326-7000, Ext. 2867

Mr. William J. Kerwin
Chief of Electronics Research Branch
Ames Research Center - N-213-4
Moffett Field
961-1111

Mr. W. K. F. Lee, Supervisor
Calibration Laboratory
United Technology Center
1050 East Arques Avenue, Sunnyvale
778-8881, Ext. 2455

Mr. Robert A. Mason
Director of Communications
Santa Clara County
2700 Carol Drive, San Jose
299-1211

Mr. A. L. Scheideler
Atomic Power Equipment Dept.
General Electric Company
175 Curtner Avenue, San Jose
297-3000, Ext. 2546

Mr. Arthur Scholar
Transmission Engineer
Pacific Telephone & Telegraph Co.
111 North Market Street, San Jose
288-9000

Mr. Jack A. Winchell
Dept. 58-64, Bldg. 151
Lockheed Missiles & Space Co.
P. O. Box 504, Sunnyvale
742-2640

WEST VALLEY COLLEGE
379-1733
Mr. Joseph T. Livingstone
Electronics Technology Instructor

Mr. Joseph A. Markum, Jr.
Electronics Technology Instructor

Mr. Robert Fell
Electronics Technology Instructor

MEETING SCHEDULE:
Called as needed.

Food Services and Restaurant Management



The enormous size of the food service industry makes it one of our most important. In California, the food and beverage business ranks fourth in the nation. The WVC program is designed to meet the needs of the industry for technically and professionally trained personnel in mid-management. An internship program is offered during the sophomore year in order to provide the student with some of the many experiences found in the restaurant industry.

ADVISORY COMMITTEE

Mr. Hal Bohannon
Bohannon's Restaurant
1401 So. First Street, San Jose
292-1266

Dr. Edwin C. Browne
Formerly Dean, S.F. City College
319 Andrews Street, Los Gatos
354-4285

Mr. Bob Buckley
17 West
34 Rosemary, San Jose
298-5000

Mr. William Cristal, Action Sales
361 Santa Clara St., San Jose
297-0130

Mr. Michael Dolan, Spartan Cafeteria
San Jose State College
125 So. 7th Street, San Jose
294-6414

Mr. David Down, Keystone Co.
57 Bassett Street, San Jose
294-4939

Mr. John Hernan, Restaurant Supply
210 San Jose Avenue, Bldg. 19
San Jose
287-1571

Mr. David Hoff
Cooks & Waiters Local #180
1121 E. Santa Clara, San Jose

Mr. Jay W. Hurlburt, The Menu Tree
2550 El Camino Real, Mt. View
941-4343

Mr. James Kaufman
Almaden Vineyards, Inc.
Public Relations Department
One Maritime Plaza, San Francisco
YU-1-3700

Mr. Walter A. Raich
Paul Masson Champagne Cellars
13150 Saratoga Avenue, Saratoga
257-0898

Mr. Cliff Toner
Canteen Food & Vending Service
1785 Rogers Avenue, San Jose
292-6640

Mr. Stan Veltman
Cable Car Caterers
1474 Berger Dr., San Jose
286-5860

Mr. Max Walden
Old Town Fine Arts Center
50 University Ave., Los Gatos
354-6601

Mr. Richard Zappelli
Zappelli's Fidelity Meat Co.
1035 Pepitone Street, San Jose
293-3883

WEST VALLEY COLLEGE
379-1733

Dr. Gordon Aumack, Dean
Instructional Division

Mr. Thomas A. Devins, Coordinator
Food Service & Restaurant Mgt.

MEETING SCHEDULE:
Called as Needed.

Institutional Foods

The need for skilled personnel, ranging from preparation of quantity foods to the management of such service operations as school cafeteria programs, hospital food services, and other food service facilities, has been especially felt in the Greater Bay Area in recent years. WVC has offered special in-service summer programs for school cafeteria employees during the past two years and is prepared to expand this service on the new Saratoga campus should such a need be indicated.

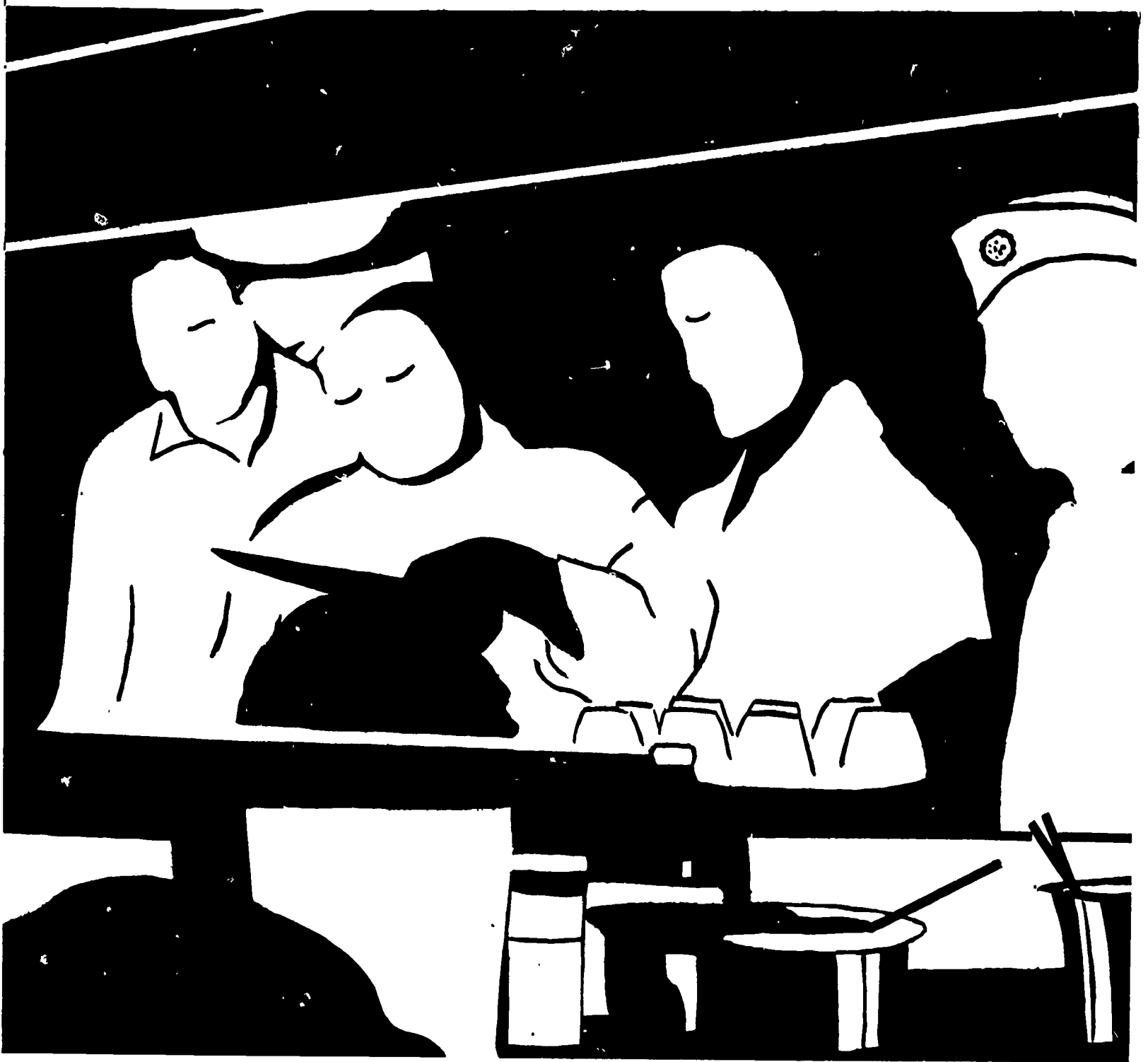

ADVISORY COMMITTEE

Mrs. Janice Bowerman
 Food Services Supervisor
 Cupertino Union School District
 10300 Vista Drive, Cupertino
 252-3000 Ext. 41 or 50

Mrs. Gertrude Buchanan
 Supervisor of Cafeterias
 Los Gatos Joint Union High School Dist.
 High School Court, Los Gatos
 354-2730 or 867-3411

Mrs. Pearl Calabrese
 Supervisor of Cafeterias
 Campbell Union Elementary School Dist.
 155 North Third Street, Campbell
 378-3496

Mrs. Thelma Dalmon
 Live Oak School District
 1959 Merrill Dr., Santa Cruz
 475-6333

Mrs. Eleanor Gleed
 Food Services Supervisor
 Campbell Union High School District
 1945 Winchester Blvd., Campbell
 379-4710

Mrs. Rosetta Holland
 Director of Food Services
 San Jose Unified School District
 1605 Park Avenue, San Jose
 293-5303 Ext. 251

Mrs. Olga Madison
 Director of Food Services
 Fremont Unified School District
 611 Olive Avenue, Fremont
 657-2350

MEETING SCHEDULE:
 Called as Needed.

Mrs. Carol Monroe
 Supervisor of Cafeterias
 Alum Rock Union Elem. School Dist.
 2930 Gay Avenue, San Jose
 258-4923 Ext. 266

Mrs. Jessie Norris
 San Lorenzo Valley School District
 P. O. Box 488, Felton
 336-5103

Mrs. Mary Puppo
 Food Services Supervisor
 Morgan Hill Unified School District
 5 East Second Street, Morgan Hill
 779-3176

Mrs. Violet I. Roefs
 Supervising Nutritionist
 School Lunch Program
 State Department of Education
 721 Capitol Mall, Sacramento
 916-445-8312

Mrs. Edna Rosa
 Food Services Supervisor
 Sunnyvale School District
 656 East Maude Avenue, Sunnyvale
 736-4981

Mrs. A'Dele Sturtevant
 Director of Food Services
 Redwood City School District
 400 Duane Street, Redwood City
 365-1550

Mrs. Dorothy Vogel
 Food Services Supervisor
 Santa Clara Co. Unified School Dist.
 P. O. Box 397, Santa Clara
 246-2100

WEST VALLEY COLLEGE
 379-1733
 Nero Pruitt
 Dean of Extended Day

Law Enforcement



Law enforcement problems continue to be rendered more acute by the rapidly expanding population, by the concentration of people in urban areas, and by the many sides of our complex society. Today's world demands a law enforcement officer who has an excellent knowledge and understanding of human relations. The trend toward better salaries, plus modern, up-to-date facilities and equipment, provides for dignified living and an honorable profession. The college-trained officer is and will continue to be in great demand.

The Law Enforcement Program at West Valley College was organized to meet the growing need for such highly skilled individuals. It is approved by the California Commission on Peace Officers' Standards and Training.

ADVISORY COMMITTEE

Capt. Robert H. Bash
Santa Clara City Police Dept.
Santa Clara Civic Center
Santa Clara
244-1400

Lt. W. A. Rasmussen
California Highway Patrol
680 Commercial Street, San Jose
295-1023

Sgt. James J. Guido
San Jose Police Department
North First & Mission, San Jose
292-3141

Lt. Thomas J. Rosa
Santa Clara County Sheriff's Office
180 West Hedding, San Jose
294-1334

Sgt. Arthur E. Knopf
San Jose Police Department
North First & Mission, San Jose
292-3141

WEST VALLEY COLLEGE
379-1733

Mr. Harold E. Welborn
Police Science Program

Chief John D. Morgan
Campbell Police Department
75 N. Central Avenue, Campbell
378-8141

MEETING SCHEDULE:
Called as Needed.

Chief Ralph M. Phillips
Los Gatos Police Department
110 E. Main, Los Gatos
354-8600

Licensed Vocational Nursing



The Vocational Nursing Course is designed to develop nursing skills which will enable the student to administer competent total-patient care.

Licensed Vocational Nurses work under the supervision of the physician or registered nurse in a variety of situations. These positions are available in doctors' offices, private homes, convalescent hospitals, general hospitals, public health nursing, rehabilitation clinics and many industries.

ADVISORY COMMITTEE

Mrs. Helen Cain
211 Kensington Way, Los Gatos
377-7038

Mrs. Catharine Dunham
486 Novato Street, Sunnyvale
245-6046

Mr. Mel Estrada
Director of Vocational Education
Campbell Union High School District
275 E. Campbell Avenue, Campbell
379-4710

Mrs. Gertrude B. Gentile
Director of Nurses
Community Hosp. Los Gatos-Saratoga
815 Pollard Road, Los Gatos
378-6131

Mrs. Irene S. Homan
Manpower Training Specialist
San Jose Employment Service
970 West Julian, San Jose

Mrs. Kathryn Hooker
139 Spring Street, Los Gatos
354-2234

Stanley L. Johnson, M. D.
240 Oak Meadow Drive, Los Gatos
378-6131

Mr. Frederic C LeRocker, Admr.
Community Hosp. Los Gatos-Saratoga
815 Pollard Road, Los Gatos
378-6131

Donald E. McCleve, M. D.
15861 Winchester Avenue, Los Gatos
356-5121

Malcolm R. Parker, M. D.
5150 Graves Avenue, San Jose
252-2511

John Rieger, M. D.
430 Monterey Avenue, Los Gatos
354-7575

Mrs. Stewart L. Rosendale
18485 Allendale Avenue, Saratoga
378-9602

Mrs. Leo Stewart
1244 Tudor Court, San Jose
258-8724

Miss Margaret Toohey
Director of Nursing Service
Kaiser Hospital
900 Kiely Blvd., Santa Clara
244-5500

Allen S. Vishoot, M. D.
264 Saratoga Avenue, Los Gatos
354-8620

WEST VALLEY COLLEGE
379-1733

Dr. Gordon D. Aumack, Dean of Instr.
Mrs. Helene Flolo, Instr.
Mrs. Doris Hawks, Instr.
Mrs. Eunice E. Hedrick, Instr.
Mrs. Evelyn Riegert, Instr.

MEETING SCHEDULE
Called as needed.

Medical Assisting



In the Bay Area particularly, where there is a growing expansion of population, the future is indeed bright for employment of medical assistants. The demand is far ahead of the supply and there is little indication that this trend will be altered in the foreseeable future. Since the medical assistant is a key person to the successful physician, she will continue to be well paid for her services in this most gratifying profession.

ADVISORY COMMITTEE

Mrs. Barbara Andrews
Good Samaritan Hospital
871 Goodwin Avenue
San Jose
371-0500

Howard W. Christopher, M.D.
621 East Campbell Avenue
Campbell
378-8412

John K. Colwell, M.D.
15955 Samaritan Drive, San Jose
356-6400

Mr. Joseph Donovan
Santa Clara County Medical Society
700 Empey Way, San Jose
286-5050

Foy W. Green, M.D.
15066 Los Gatos-Almaden Road
Los Gatos
377-9180

Glen S. Harman, M.D.
431 Monterey Avenue
Los Gatos
354-1424

Benson R. McGann, M.D., Chrm.
Santa Clara Medical Society Advisory
to Medical Assistants Society
747 Altos Oaks Drive, Los Altos
948-7777

Mrs. Angela Miniotta, Educ. Chrm.
California Medical Assistants Assoc.
1087 Park Avenue, San Jose
292-5151

Richard C. Rhodes, M.D.
1706 Willow Street, San Jose
266-6160

WEST VALLEY COLLEGE
379-1733

Miss Portia Frederick, Instructor
Medical Assisting

Mrs. Marilyn Rasmussen, Instructor
Medical Assisting

Mrs. Jean Doyle, Instructor
Medical Assisting

MEETING SCHEDULE:
Called as Needed.

Real Estate

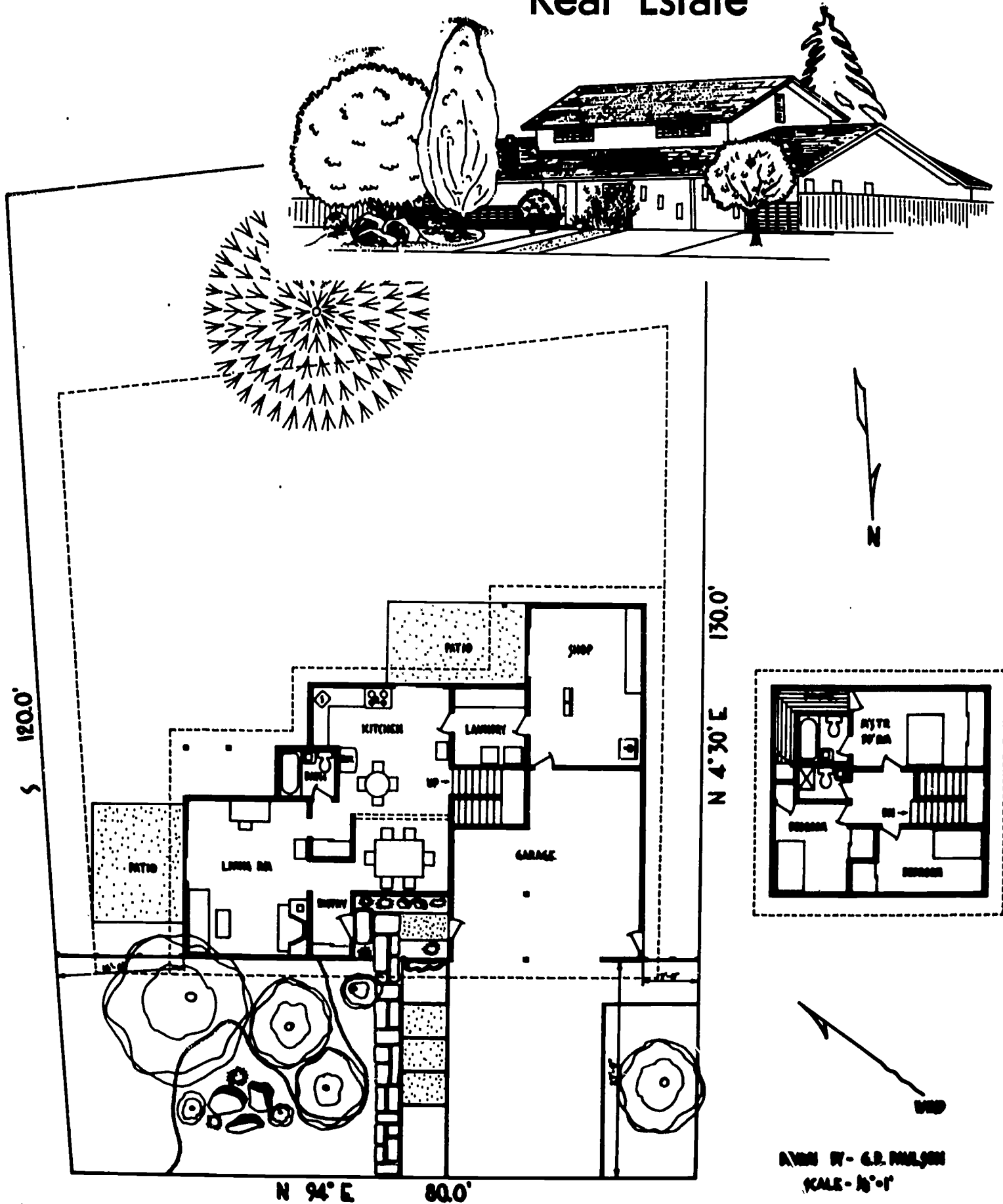

The Santa Clara Valley area is one of the fastest growing areas in California, and this has significant implications for the field of real estate. There is a continuing need for well trained brokers and sales personnel as well as for better informed personnel in such related occupations as finance and construction.

Most of the members of the Real Estate Education Advisory Committee are Realtors and sales personnel who are closely identified with the two local real estate boards, but the other related occupational fields are also represented. The close working relationship which has been developed between the college and the real estate industry is the direct result of the efforts of all the members of this committee.

ADVISORY COMMITTEE

Mr. James R. Barrow
488 South 10th St. , San Jose
292-9400

Mr. William P. Cunningham, Jr.
5286 Woodstock Way, San Jose
269-1589

Mr. Donald D. Cooley
1279 Burkette Drive, San Jose
296-5974

Mr. Emmette T. Gatewood, Jr.
260 Saratoga Avenue, Los Gatos
354-2740

Mr. Edwin V. Jacobsen
Edwin V. Jacobsen
Investment Properties
1807 Pruneridge Avenue, Santa Clara
241-2273

Mr. Edward A. Kolstad
Saratoga Properties, Inc.
20432 Saratoga-Los Gatos Road
Saratoga
867-4766

Mr. Morris Loughran
Saratoga Village Realty
14477 Big Basin Way, Saratoga
252-2734

Mr. Robert C. Moore
Robert C. Moore and Associates
1777 Saratoga Avenue, San Jose
257-1520

MEETING SCHEDULE:
2nd Tuesday of each month, 4:00 p.m.

Mr. Kenneth C. Root
Ken Root Realtor
1080 Lincoln Avenue, San Jose
292-7370

Mrs. Connie R. Russo
Pines Plaza Realty
100 W. Rincon Avenue, Campbell
378-0889

Mr. Theodore L. Shebs
Norman O'Connor Agency
225 Saratoga Avenue, Los Gatos
354-9520

Mr. Cecil J. Silva
Cecil Silva Mortgage Company
1799 Hamilton Avenue, San Jose
269-6941

Mr. Richard Van Valer
2060 Forest Avenue, San Jose
297-3915

Mr. Holland A. Vollenweider
Vollenweider Realty
2050 S. Bascom Avenue, Campbell
377-2462

Mr. Shelley Williams, Jr., Chairman
Shelley Williams Associates, Inc.
12960 Saratoga-Sunnyvale Road
Saratoga
867-3414

WEST VALLEY COLLEGE
379-1733

Dr. Gordon D. Aumack-Dean, Instr.

Mr. Nero Pruitt-Dean, Ext. Day

Secretarial

The busy executive in today's complex business world has long been aware of the important role played by the competent secretary. Well-qualified typists seem to be available, but the young woman who is capable of being a real assistant to her employer is a rare and valuable asset to any staff. Working conditions are usually pleasant and salaries for top-level secretaries are high.

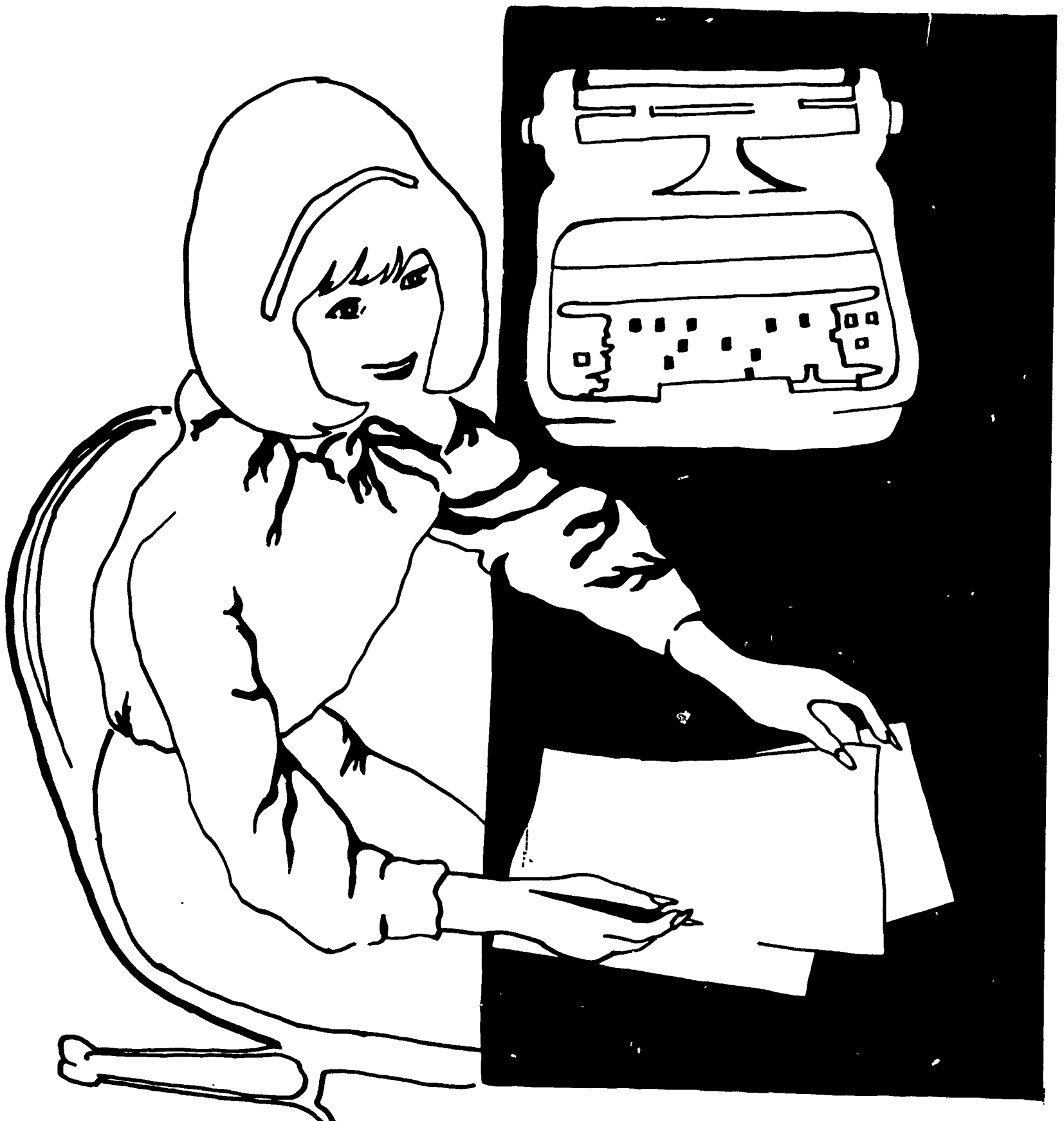

ADVISORY COMMITTEE

Mr. Milton Abel
 Manager, Secretarial Services
 IBM Corporation
 Monterey and Cottle Roads, San Jose
 227-7100

Mrs. Gail L. Dunham
 School Representative
 Pacific Telephone Company
 234 Carroll, Sunnyvale
 288-9000, Ext. 3162

Mrs. Dorothy Hill, Secretary to
 Specialist, Educ. & Com. Relations
 General Electric Company
 175 Curtner Avenue, San Jose
 297-3000, Ext. 2020

Mr. Roland O. Hill
 Manpower, Inc., Calif. Peninsula
 P. O. Box 5966, San Jose
 266-4220

Mrs. Donna Koelsch, CPS
 IBM Corporation
 Office of Counsel, Department 815
 Monterey and Cottle Roads, San Jose
 227-7100

Mr. E. L. Lantz, Manager
 Extraction Operations
 Intl. Minerals & Chemical Corp.
 1931 South Monterey Road, San Jose
 294-4130

Mrs. Alice Larsen
 Department 27113, Building 530
 Lockheed Missiles and Space Company
 P. O. Box 504, Sunnyvale
 742-6146

MEETING SCHEDULE:
 Called as Needed.

Mr. D. J. Lowe
 Employment Supervisor
 Food Machinery Corporation
 1105 Coleman Avenue, San Jose
 289-0111

Mr. Thomas A. Morrison
 Personnel Assistant
 Pacific Gas and Electric Company
 86 South Third Street, San Jose
 298-3333

Mr. T. S. Motheral, Supervisor
 Personnel Development and Benefit
 Administration
 Sylvania Electronic Systems
 P. O. Box 188, Mountain View
 966-9111

Miss Nancy Peterson
 Employment Manager
 Varian Associates
 611 Hansen Way, Palo Alto
 326-4000

Mr. J. R. Walser
 Heald Business College
 10 Notre Dame Avenue, San Jose
 294-1964

WEST VALLEY COLLEGE
 379-1733

Mrs. B. Cunningham, Instructor
 Mrs. D. Dake, Instructor
 Mrs. B. Lea, Instructor
 Mrs. D. Mayfield, Instructor
 Mrs. D. O'Brien Employment Sec.
 Mr. K. Schock, Bus. Div. Chrm.
 Mrs. M. Van Peborgh, Counselor

Technical Drafting

The increasing complexity of industrial technology has created a need for trained personnel at the beginning draftsman levels. The function of these persons is to create the detail working drawings necessary to produce the company product. All manufacturing, construction and service concerns will have one or more draftsmen in their employ. In recent years, job placement opportunities in Santa Clara County have risen in direct relationship to the skills acquired by the student.

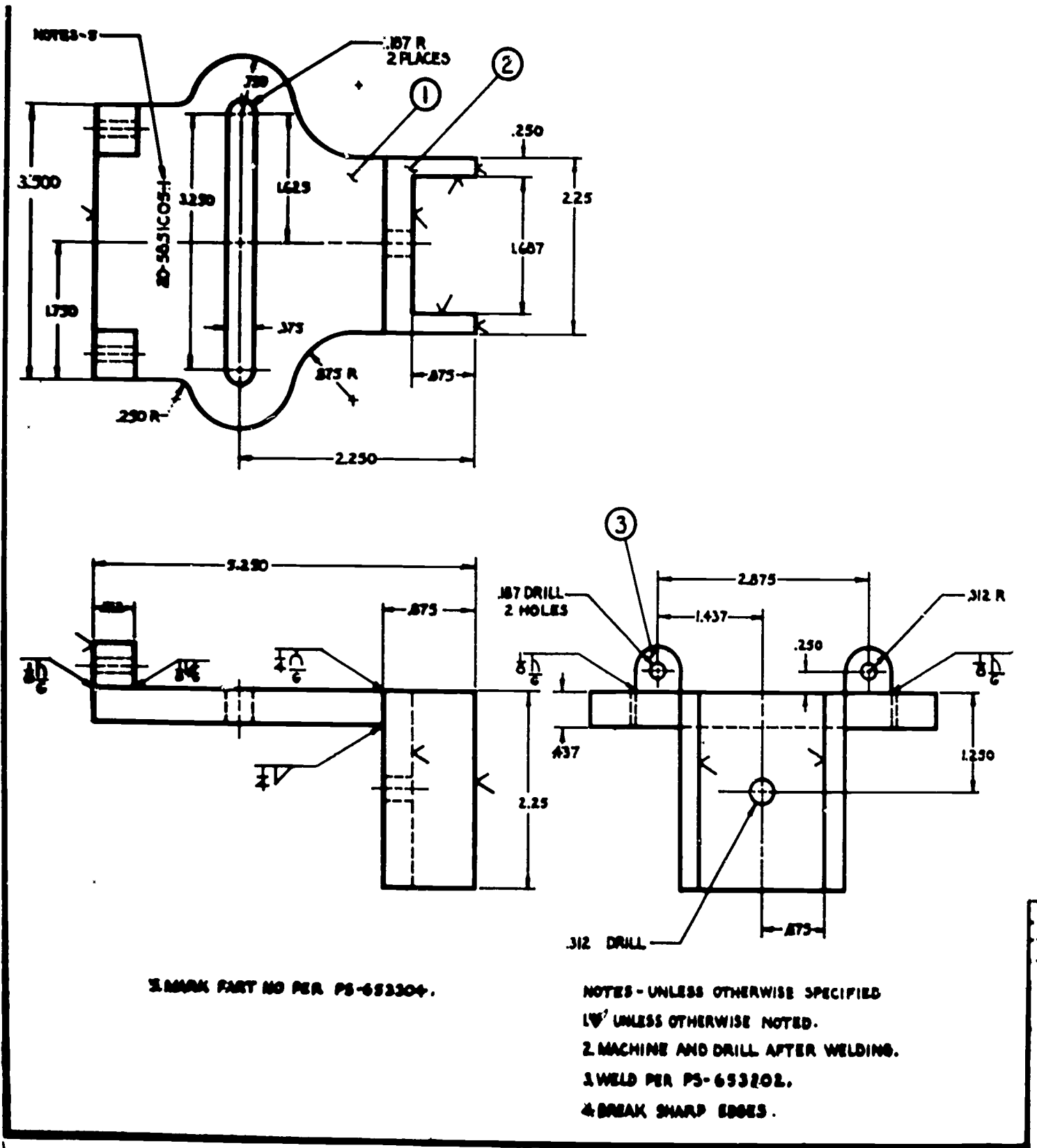

ADVISORY COMMITTEE

Mr. M. C. Carey
 Philco Corporation Design Department
 3838 Fabian Way - MS-C47, Palo Alto
 326-4350, ext. 4443
 (alternate; Mr. E. J. Clark) ext. 4728

Mr. Jerry Hicks IBM
 Dept. 553C, Bldg. 014
 Monterey & Cottle Roads, San Jose
 227-7100, ext. 6959
 (alternate; Mr. Bill Souza 553A)

Mr. Richard Congdon
 Chief, Drafting Services U. T. C.
 1050 E. Arques Avenue, Sunnyvale
 739-4880, ext. 3374
 (alternate; Mr. Myron Heath,
 Supr. Draftg.)

Mr. Guy Hill
 General Electric Co.
 175 Curtner Avenue
 Bldg. K - Room 23M, San Jose
 297-3000, ext. 2023
 (alternate; Mr. John Ryan, K 23Y)

Mr. Gene Dahl
 Ampex Corporation
 401 Broadway M. S. 3-52
 Redwood City
 367-2011, ext. 2215

Mr. Edgar Johnson
 FMC Ordnance Division
 P. O. Box 367, San Jose
 289-3411
 (alternate; Mr. Carl Lance) 289-2711

Mr. Ken Dunn
 Watkins Johnson Co.
 3333 Hillview Avenue, Palo Alto
 326-8830

Mr. Earle Lewis A. I. A.
 586 N. First Street, San Jose
 294-9620

Mr. Hal Hartman
 Sylvania Electrical Products
 R. S. L. Box 188, Mt. View
 966-2554
 (alternate; Mr. Richard Buddington,
 Chief Draftsman)

Mr. James McCoy, City of San Jose
 Room 316, City Hall
 North First & Mission Streets, San Jose
 292-3141, ext. 681
 (alternate; Mr. Ed Louis)

Mr. Irving Michelson
Fairchild Semiconductor
4001 Junipero Serra, Palo Alto
321-7250, ext. 2162

Mr. Tom Wild
Westinghouse Electric Company
Hendy Avenue, Sunnyvale
735-2301
(alternate; Mr. Neo Corsini)

Mr. Jack Nall
Lockheed Missile Systems Division
Organization 27-13 - Educ. Bldg. 515
Sunnyvale
742-3030
(alternates; Mr. Robert Fierro
Mr. Ralph Maggio)

Consultants

Mr. James C. Babcock
Drafting Department
San Jose State College, San Jose
294-6414, ext. 2305
(alternate; Mr. Ralph Norman, Prof.)

Mr. Mel Estrada, Dir. Voc. Educ.
Campbell Union High School Dist.
275 E. Campbell Avenue, Campbell
379-4710
(alternate; Mr. Frank Meiss)

Mr. Howard Biebeshheimer
San Jose City College
2100 Moorpark Avenue, San Jose
298-2181
(alternates; Mr. Andrew McFarlin
Mr. Bud Tollefson)

Mr. James Schilling, Drafting Instr.
Ohlone College
Mission Blvd., Fremont
657-2100, ext. 51

Mr. Lionel Cross
San Jose Unified School District
1605 Park Avenue, San Jose
293-5303, ext. 204

WEST VALLEY COLLEGE
379-1733

Mr. Ted Geredes
(alternate; Mr. Charles Tyler)

MEETING SCHEDULE:
Called as Needed.

Technical Illustration

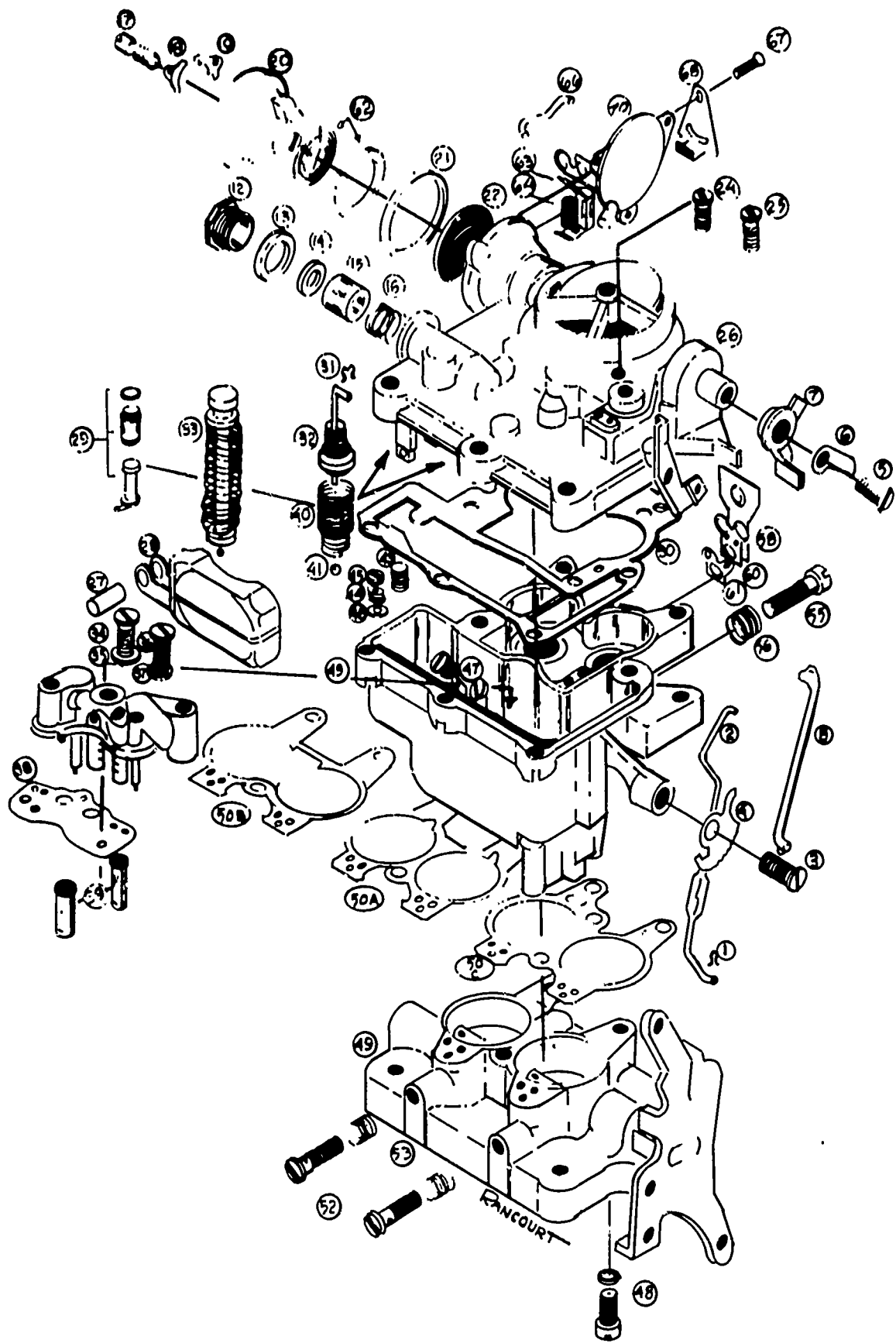

ROCHESTER CARBURETOR

1 RETAINER-PUMP ROD LWR
 2 ROD-PUMP
 3 SCREW FAST IDLE CAM
 4 CAM FAST IDLE
 5 SCREW TRIP LEVER
 6 LEVER-TRIP
 7 LEVER & COLLAR-CHOKE
 8 ROD CHOKE
 9 SCREW IDLE VENT VALVE

19 RETAINER-SCAT COVER PLAIN
 20 STAT COVER & SPRING ASSY.
 21 GASKET-STAT COVER
 22 PLATE CHOKE BAFFLE
 23 GASKET CHOKE HOUSING(NS)
 24 SCREW & LOCKWASHER BOWL(L)
 25 SCREW & LOCKWASHER
 26 BOWL COVER ASSY.
 27 PIN-FLOAT HINGE

37 VENTURI CLUSTER ASSY.
 38 GASKET CLUSTER ASSY.
 39 INSERT-MAIN WELL
 40 SPRING-PUMP RETURN
 41 BALL-PUMP INTAKE
 42 GUIDE PUMP DISCHARGE BALL
 43 SPRING DISCHARGE BALL
 44 BALL-PUMP DISCHARGE
 45 VALVE ASSY-POWER

55 NEEDLE IDLE AIR ADJUST
 56 SPRING NEEDLE AIR ADJUST
 57 SCREW OVER COMPENSATOR
 58 COVER IDLE COMPENSATOR
 59 SRV IDLE COMPENSATOR VALVE
 60 VALVE IDLE COMPENSATOR
 61 GASKET IDLE COMPENSATOR
 62 STAT COV. & SPRING ASSY
 63 RETAINER-FILTER

The drafting laboratories at West Valley College are equipped with up-to-date drafting and reproduction equipment. The nature of the technical illustration course is such that a maximum of individual attention is given to each student. Field trips are employed to acquaint the student with actual working conditions and outstanding architects, draftsmen, illustrators and engineers are brought in as guest lecturers. Students often are asked to engage in a friendly intra-class competition in the exercise of a particular design or drafting assignment for student or other campus use.

ADVISORY COMMITTEE

Mr. Carl A. Bergren
Food Machinery Corporation
1105 Coleman Avenue, San Jose
289-3129

Mr. Wil Gibbs
Dept. of Technical Drawing
San Jose City College
2100 Moorpark Avenue, San Jose
298-2181

Mr. Malcolm Gilmour
Westinghouse Corporation
P. O. Box 1223, Los Gatos
735-2386

Mr. Bob Grewohl, Instructor
Los Gatos High School
Los Gatos
354-2730

Mr. Gerald Hansen, Instructor
Saratoga High School
P. O. Box 68, Saratoga
867-3411

Mr. Dale Hart
Philco-Ford Corp., W. D. L. Div.
3825 Fabian Way, Palo Alto
326-4350, Ext. 6330

Mr. Joe Kirk
I. B. M.
1193 Runnymede Drive, San Jose
227-7100, Ext. 7298

MEETING SCHEDULE:
Called as Needed.

Mr. W. H. Mattinson
Lockheed Missiles & Space Co.
Dept. 82-73, Bldg. 536
P. O. Box 504, Sunnyvale
742-2438

Mr. Howard Petrey
Lockheed Missiles & Space Co.
Dept. 82-73, Bldg. 536
P. O. Box 504, Sunnyvale
378-4152

Mr. Hal Thomas
Composite Arts
20061 Bollinger Road, Cupertino
253-8323

Mr. Irving Webster
Sylvania
2459 Tamalpais Street
Mountain View
966-3940

Mr. Monroe Winston
Associated Techdata, Inc.
2905 El Camino Real, Palo Alto
324-4401, Ext. 50

WEST VALLEY COLLEGE
379-1733

Mr. Theodore Geredes, Instructor
Technical Illustration

Mr. Weston H. Kingsley, Instructor
Technical Drafting

Mr. A. Charles Tyler, Instructor
Technical Illustration

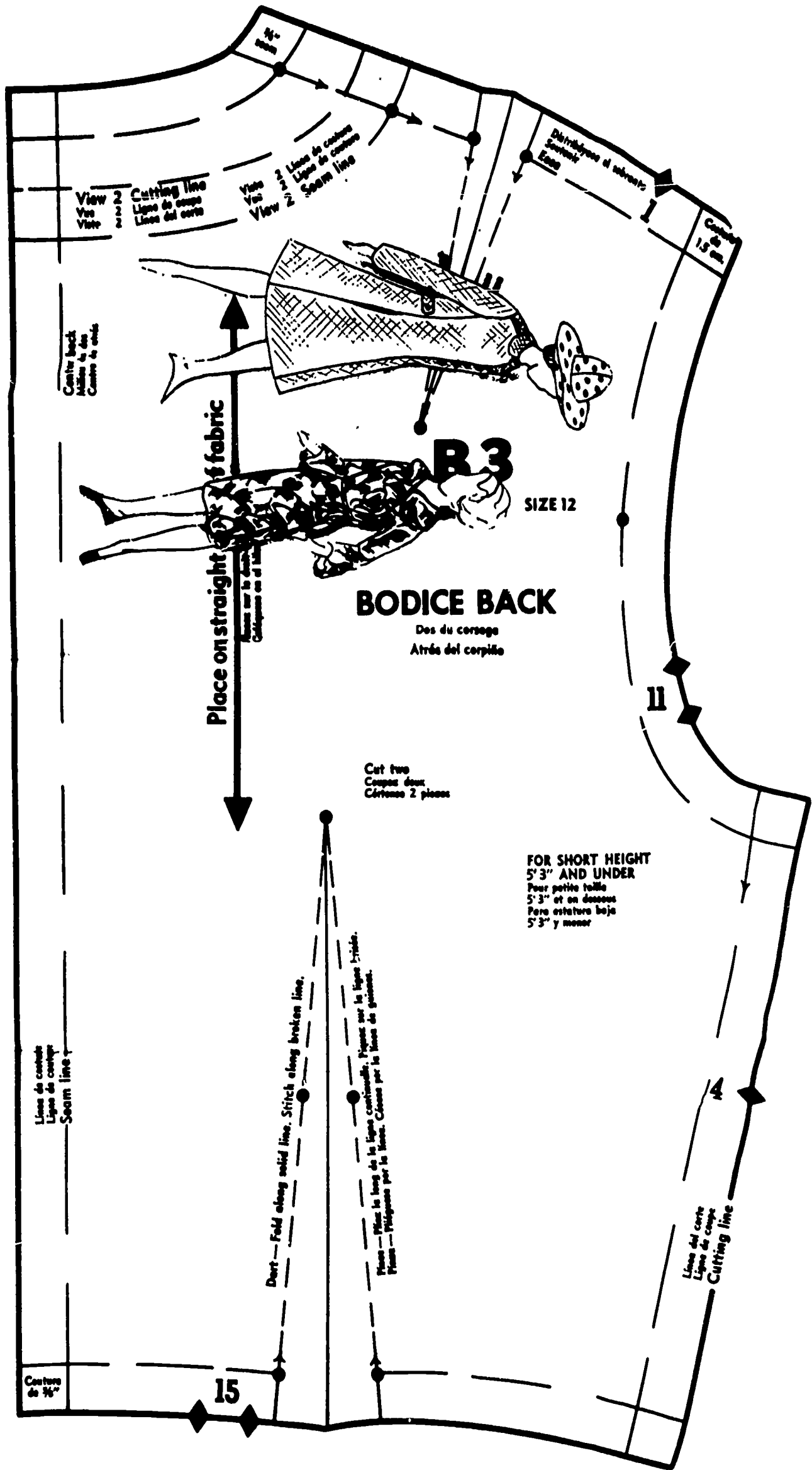

One of the largest industries in the world, the textile and clothing field, offers many exciting and rewarding careers for salespersons, clothing buyers, merchandise managers, journalists, seamstresses or designers.

ADVISORY COMMITTEE

Mr. Gene Bowles
 Manager, Display Department
 Breuner's Home Furnishings
 525 East Hamilton Avenue
 Campbell
 378-9400

Mrs. Madge Drews
 Personnel Manager
 Macy's at Valley Fair
 2801 Stevens Creek Road
 San Jose
 248-3333

Mrs. Marjory Harvey
 Personnel Manager
 Sears, Roebuck & Co.
 1350 W. San Carlos, San Jose
 295-6705

Mr. Earl W. Norris
 Norris Fabric Store
 316 Town & Country Village
 San Jose
 243-1787

WEST VALLEY COLLEGE
 379-1733

Mrs. Jean Denny, Instructor
 Home Economics

Mrs. Katherine Gooch
 Financial Aids Officer

Mrs. Gwenna Mortensen, Instructor
 Home Economics

Miss Rita Storey, Instructor
 Home Economics

MEETING SCHEDULE:
 Called as Needed.

The All-College Advisory Committee

37

In addition to the several Advisory Committees serving special educational needs in the Engineering Technology Division, a large advisory committee has been organized to work directly with administrators and the Board of Trustees. The West Valley College Advisory Committee assists in the development and growth of the college. This group of representative businessmen, professional people and public officials act in a guidance and advisory capacity on such matters as the Governing Board desires to present to them from time to time.

Mr. Myron E. Alexander, Realtor
393 E. Hamilton Ave., Campbell
379-7720

Judge Bruce F. Allen
Superior Court Judge
20130 Thompson Road, Los Gatos
299-1121

Mr. Roger Brennan
Exec. Sec'y, Bldg. & Constr. Trades
Council
370 Umbarger Rd., San Jose
225-4494

Dr. Edwin C. Browne
Former Dean, S. F. City College
319 Andrews St., Los Gatos
354-4285

Mr. Halsey C. Burke
President, Burke Rubber Co., Inc.
2250 S. 10th, San Jose
297-3500

Mrs. Mary Byington, Housewife
1422 Rosalie Dr., Santa Clara
243-4582

Mr. William H. Calker, Orchardist
16075 Matilija Drive, Los Gatos
354-1710

Mrs. John E. (Ruby) Deranja
Housewife
90 Alviso, Santa Clara
243-7637

Mrs. Lawrence (Camille) Fargher
Housewife
1755 Shamrock Ave., Santa Clara
296-2884

Mr. Daniel G. Fields
Engineer-IBM
1707 Clovis Ave., San Jose
297-2676

Mr. Emmette Gatewood, Jr.
Realtor
260 Saratoga Ave., Los Gatos
354-2740

Mrs. Virgil (Betty) Greenley
Housewife
1765 Patio Dr., San Jose
269-0733

Mr. James T. Hartigan, Bus. Rep.
Plumbers & Steamfitters Union
293 Ester Ave., Campbell
378-3286

Mr. S. G. Hernandez
Businessman, Laurel Motor Court
14626 Big Basin Way, Saratoga
867-1831

Mr. Ellis A. Howard
Manager, Wells Fargo Bank
20640 Signal Dr., Saratoga
286-3500

Mrs. Desmond (Catherine) Johnson
Housewife
18500 Twin Creeks Rd., Monte Sereno
354-3018

Judge Joseph P. Kelly
Superior Court Judge
966 Hilmar, Santa Clara
299-1121

Mr. Leon Poe, Asst. Chief Attorney
Legal Aids Society of S. C. County
235 E. Santa Clara, San Jose
298-1315

Mr. Warren H. Klippel
Engineer-IBM
19908 Glen Brae Dr., Saratoga
227-7100 Ext. 3877

Mr. Will W. Lester, Jr., Orchardist
10650 Linnet Lane, Cupertino
252-7498

Mr. John Lincoln, Manufacturer
Former Mayor of Los Gatos
58 Alpine Ave., Los Gatos
354-3371

Mrs. Jack (Ruth) Lucier, Housewife
1321 Klamath Dr., San Jose
243-0862

Mr. Gerald S. Marshall
Engineer-Sylvania
19610 Three Oaks Way, Saratoga
867-9473

Mrs. Clovis T. (Ann) Mirassou
Housewife
147 Old Orchard Rd., Los Gatos
356-4126

Dr. Robert E. Moore, Dentist
15066 Los Gatos-Almaden Road
Los Gatos
377-0407

Father Francis K. Murray
St. Frances Cabrini Church
15333 Woodard Rd., San Jose
377-2111

Mr. W. J. Nicholson
Nicholson-Brown Inc., Indus. Constr.
P. O. 390-A, Santa Clara
241-3211

Mrs. Joseph (Catherine) Richards
Housewife
2354 Glendenning Ave., Santa Clara
243-2751

Mr. Charles Rose
Businessman, Rose Television-
Radio Sales & Service
376 N. Central Ave., Campbell
378-7195

Mr. Vernon R. Rutlen, Businessman
12420 Radoyka Dr., Saratoga
252-1117

Mrs. Leo (Ruthadele) Sarter
Housewife
14713 La Rinconada Dr., Los Gatos
356-4225

Rev. Shirley T. Sherrill, Minister
1280 Peralta Dr., San Jose
Cambrian Park Methodist Church
264-8856

Mr. James St. Germaine
S. C. County Health Department
2220 Moorpark Ave., San Jose
297-1636

Mr. George Vierhus
Publisher, Campbell Press
35 Dillon Ave., Campbell
378-9136

Mr. Don R. Von Raesfeld
Mgr., City of Santa Clara
P. O. Box 388, Santa Clara
244-1400

Mr. Thomas A. Wilberding, Teacher
Santa Clara Unified School District
15285 Sobey Road, Saratoga
354-1247

Mr. Frank A. Wilcox, Rancher
1019 Coffin Rd., Santa Clara
296-3144

Mr. William A. Wilson, Jr.
Businessman, Wilson's Jewel Bakery
909 Monroe, Santa Clara
244-1956

Mr. Tack Yonemoto
Nurseryman
1328 Henderson Ave., Santa Clara
296-7050

All Illustrations in this report were prepared by the beginning technical illustration class. Special credit to the following students for their good work:

Larry Tessier-- Civil Engr. plus layout and organization

Mark Colella - Data Processing

Ron Witteveen - Electronics

Barbra Seibert - Foods Service & Rest. Management

Dave Gutierrez - Institutional Foods

Bob Pickering - Law Enforcement

Lynn Thoroughgood - Licensed Vocational Nursing

David Aquilar - Medical Assisting

Gary Paulson - Real Estate

Barbra Seibert - Secretarial/Clerical

George Craver - Technical Drafting

Steve Rancourt - Technical Illustration

Jodi Tremaine & L. Tessier - Textile/Clothing

The typing for this brochure was done in an intermediate typing class by Marjorie Klus, Kay Kuester, and Lee Ann Stewart--secretarial majors at West Valley College.